



INSTRUCTION BULLETIN

No. 9015128
Machine: M17
Published: 08-2016
Rev. 00

NOTE: DO NOT DISCARD the Parts List from the Instruction Bulletin. Place the Parts List in the appropriate place in the machine manual for future reference. Retaining the Parts List will make it easier to reorder individual parts and will save the cost of ordering an entire kit.

NOTE: Numbers in parenthesis () are reference numbers for parts listed in Bill of Materials.

Installation instructions for **kit number 9017311 / 9017314**

SYNOPSIS:

This kit contains the parts needed to install a telemetry kit on M17 sweeper- scrubbers.
Please follow step-by-step instructions.

SPECIAL TOOLS / CONSIDERATIONS: NONE

(Estimated time to complete: 2- 3 hours)

The IRIS (telemetry module) must be activated to complete this installation. The module will not function until it is activated. Call for assistance (North America - Technical Support / Australia - CCC / EU - Local IRIS Expert) activating the module after all telemetry components have been installed. Have machine serial number and IRIS module SIM number (located on back of IRIS control box assembly) ready when calling for activation.

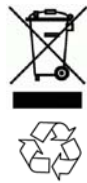

PROTECT THE ENVIRONMENT

Please dispose of packaging materials, used machine components such as batteries and fluids in an environmentally safe way according to local waste disposal regulations.

Always remember to recycle.

PREPARATION:

1. Confirm the hour meter is properly wired and functional. The hour meter must be fully functional and wired properly before the IRIS system can be installed.
2. Stop the machine on a level surface and turn off the machine.
3. Remove the brushes from the main scrub head. Set the brushes aside.
4. **Machines equipped with cylindrical brushes only:** Remove the debris trough from the back of the scrub head.

5. Turn on the machine, completely lower the scrub head, turn off the machine, set the parking brake, and remove the key.

FOR SAFETY: Before leaving or servicing machine, stop on level surface, turn off machine, set parking brake, and remove key.

6. Evaluate the condition of the battery, cables, and terminal connections. The battery / cables / terminal connections must all be in safe working condition.

7. Disconnect the battery cable from the machine.

WARNING: Always disconnect battery cables from machine before working on electrical components.

8. Remove the battery from the machine.

FOR SAFETY: When servicing machine, use a non-conductive battery removal device, use a hoist and adequate assistance when lifting batteries, battery installation must be done by trained personnel, follow site safety guidelines concerning battery removal.

9. Remove the SEMS M6 hex screws securing the electrical enclosure cover to the electrical enclosure. Set the SEMS M6 hex screws aside. (Fig. 1).

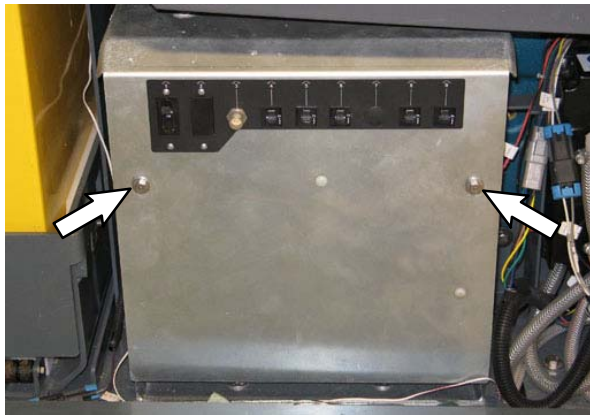

FIG. 1

10. Carefully remove the electrical enclosure cover from the electrical enclosure and position as shown. **Do Not** break or damage wires / wire connections when removing the electrical enclosure cover from the electrical enclosure. (Fig. 1 / Fig. 2)

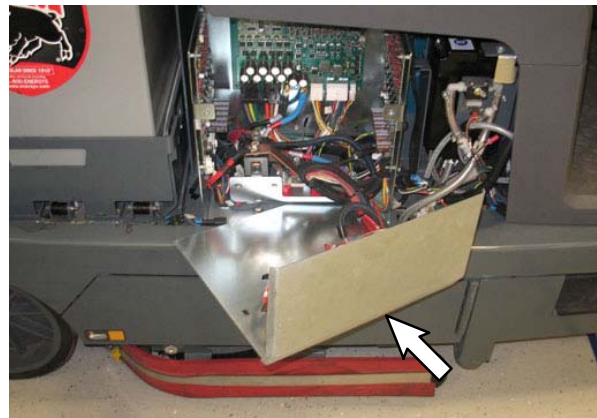

FIG. 2

11. Disconnect the existing battery cable from the 36 VDC B+ at M1 contactor and the insulated ground standoff (machine negative) inside the electrical enclosure. Set all hardware used to secure the battery cable to B+ at M1 and the machine ground aside. Discard the removed battery cable. (Fig. 3)

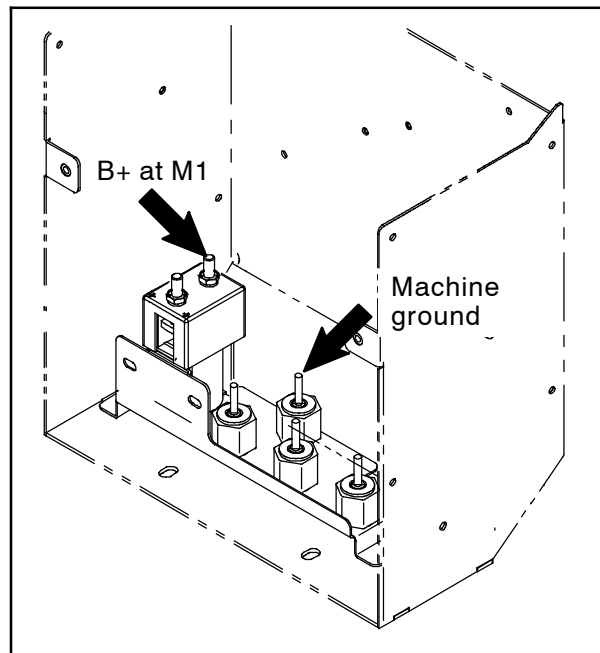

FIG. 3

12. Remove the existing battery cable from the machine. Set both M6 hex screws and both flat washers aside. Discard the removed battery cable.

INSTALLATION:

1. Use two M4 pan screws (10) to install the shunt (9) onto the recovery tank. (Fig. 6)
2. Use the saved M6 hex screws and flat washers to install the new battery cable (13) onto the battery cover. (Fig. 4 / Fig. 6)



FIG. 4

3. Route the battery cable (13) down through the three cable clamps and down to shunt (9). (Fig. 5 / Fig. 6)

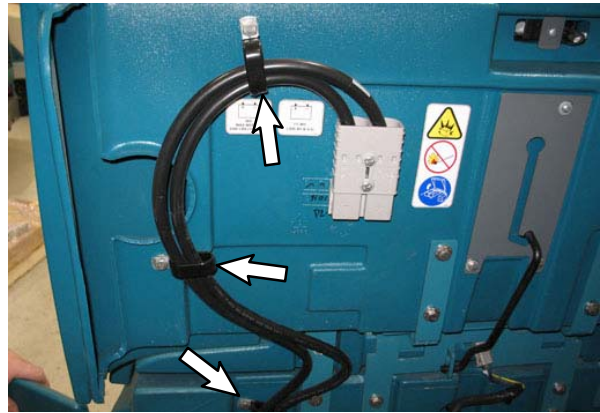

FIG. 5

4. Route the battery cable (14) to the shunt (9). (Fig. 6)
5. Connect the battery cable (13) shorter black cable to the shunt (6). (Fig. 6)
6. Connect the black cable (14) to the shunt (9). (Fig. 6)

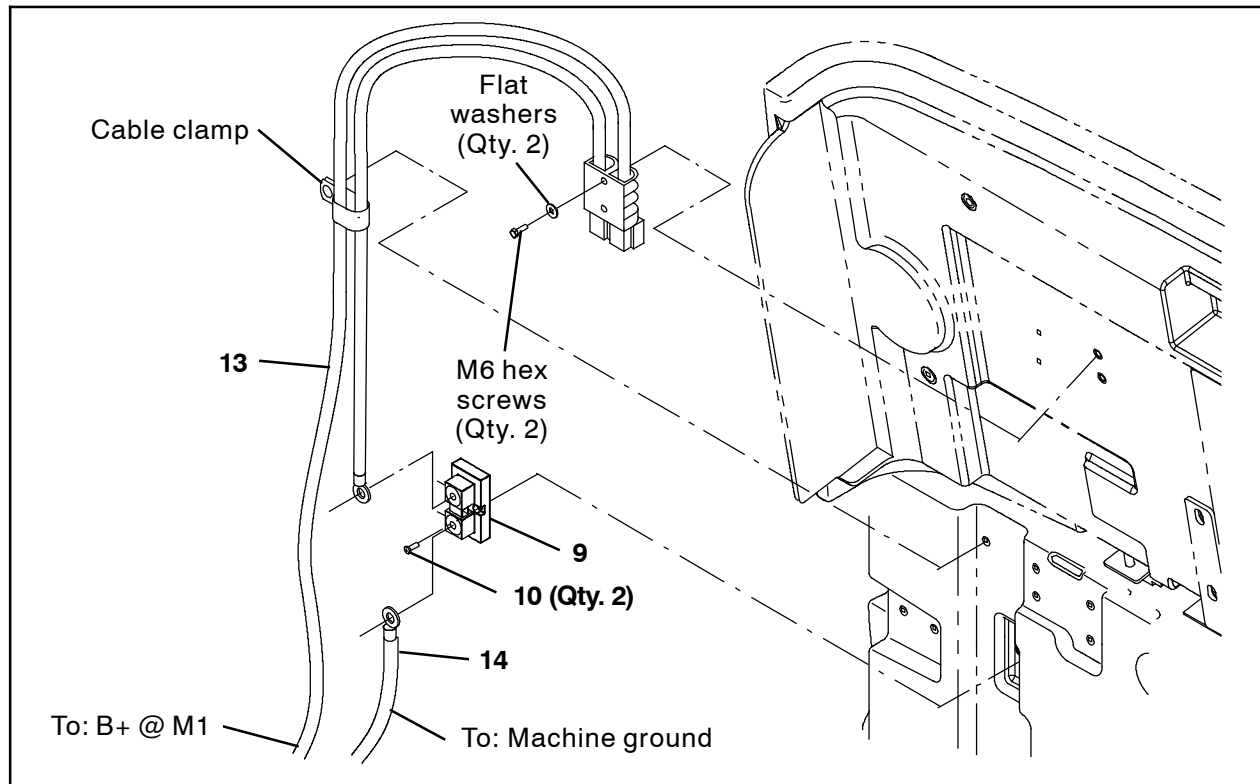

FIG. 6

7. Route the battery cable (13) red cable and the black cable (14) down towards the floor and then up along the frame of the machine to the hole in the electrical compartment. (Fig. 7 / Fig. 8)

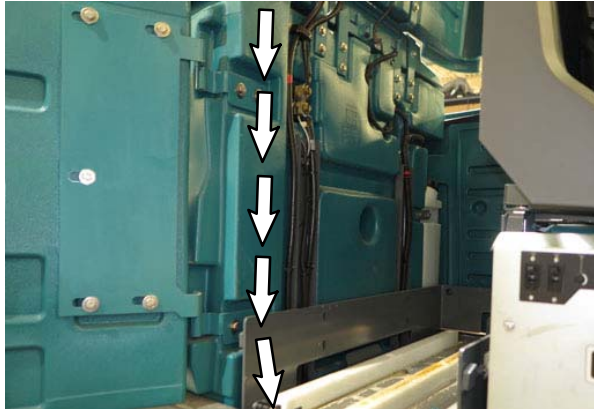

FIG. 7

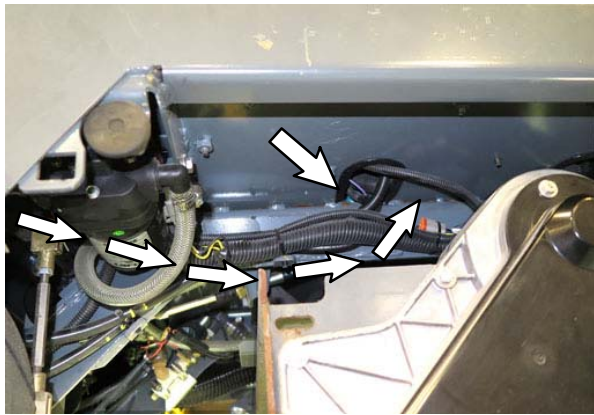

FIG. 8

8. Connect the other end of the black cable (14), connected to the shunt (9), to the insulated ground standoff (machine negative) inside the electrical enclosure. (Fig. 9 / Fig. 6)

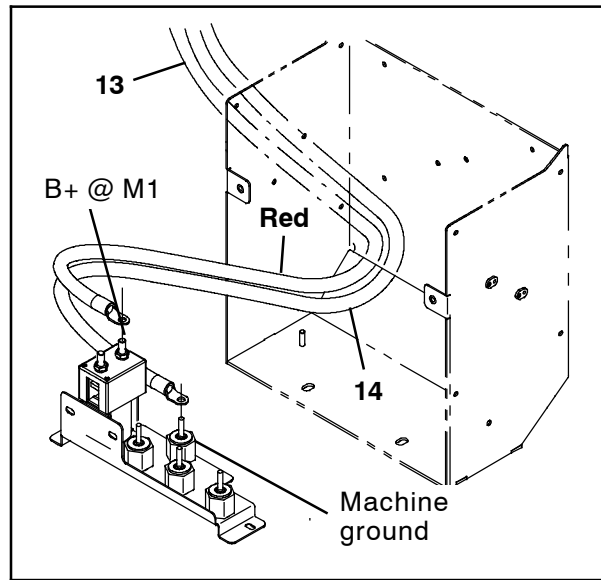

FIG. 9

9. Route the battery cable (13) red cable into the electrical enclosure and connect the red cable to the B+ at M1 location on the 36 VDC contactor. Do not completely tighten hardware. The telemetry harness (12) is connected to this location later in this bulletin. (Fig. 9 / Fig. 6)
10. Remove the additional SIM label from the back of the control box (1) and set label aside in a safe place. The number on the SIM label will be needed for activating the machine. (Fig. 10)

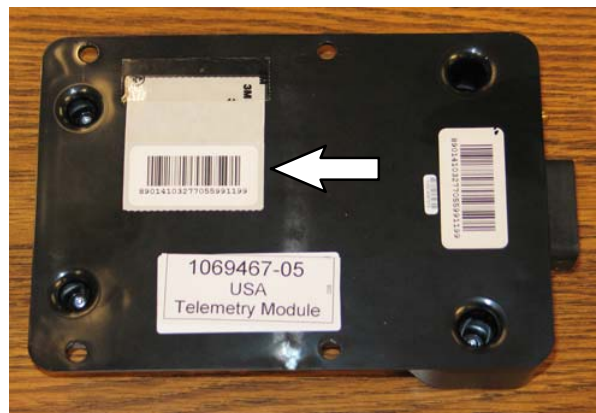

FIG. 10

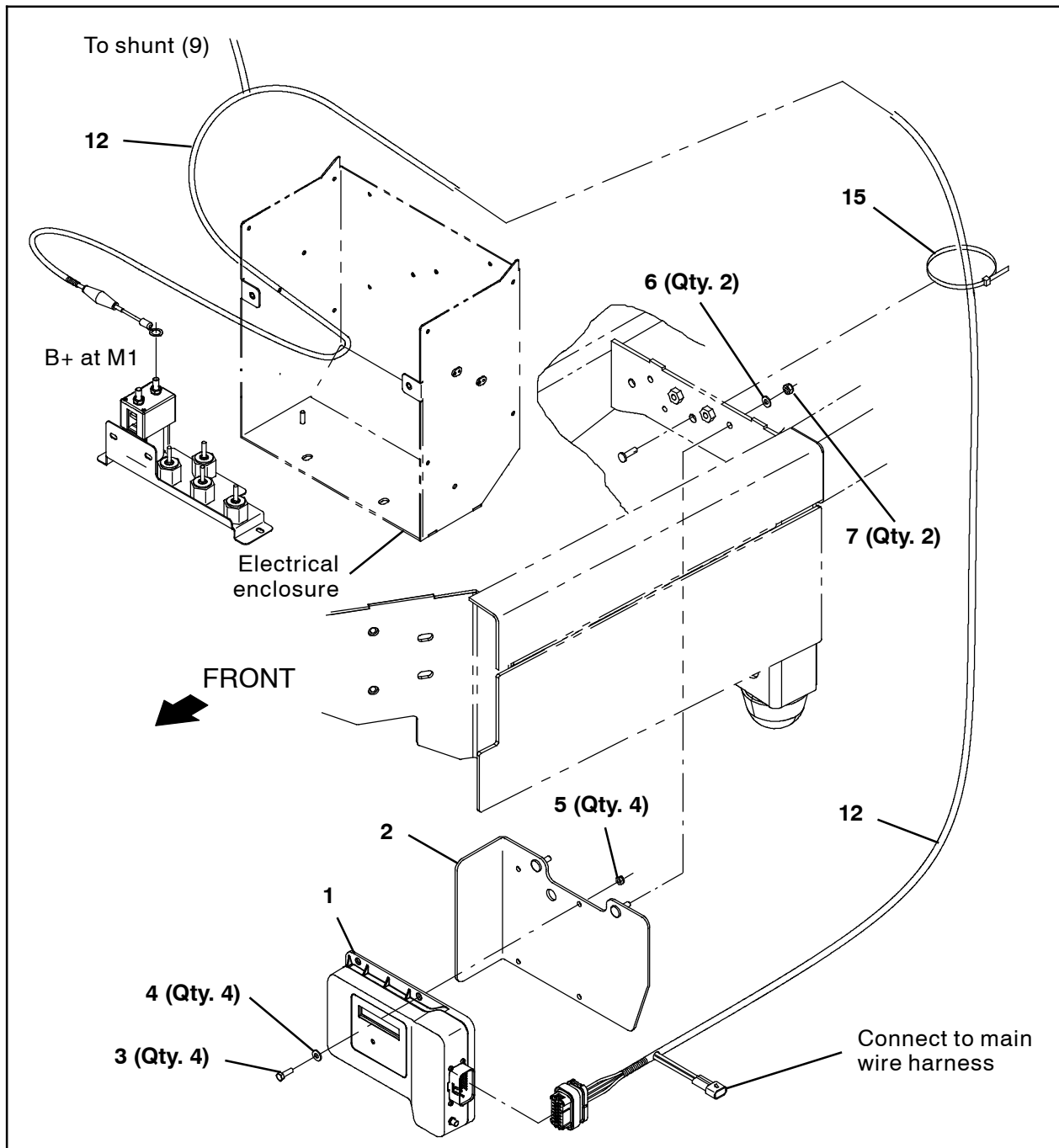

FIG. 11

11. Use four M5 hex screws (3), four flat washers (4), and four M5 hex lock nuts (5) to install the telemetry control box (1) onto the telemetry bracket (2). (Fig. 11)
12. Use two M6 hex lock nuts (7) and two flat washers (6) to install the control box (1) / telemetry bracket (2) onto the frame of the machine. (Fig. 11)
13. Connect the telemetry harness (12) to the main wire harness. (Fig. 11 / Fig. 17)
14. Use a cable tie (15) to secure the telemetry harness (12) to the frame of the machine. (Fig. 11)

INSTALLATION TIP: Secure a thin gauge wire, approximately the length of the telemetry harness (13), to the end of the telemetry harness to be connected to the shunt (9) and route the wire with the telemetry harness. This wire can then be secured to the antenna (16) cable to help route the antenna wire along the telemetry harness to the telemetry control box (1).

15. Route the telemetry harness (12) along the main wire harness / frame cross member, over the top of the scrub head, through the channel behind the scrub head, and along the opposite frame cross member to the opening in the electrical enclosure. (Fig. 12 / Fig. 13)

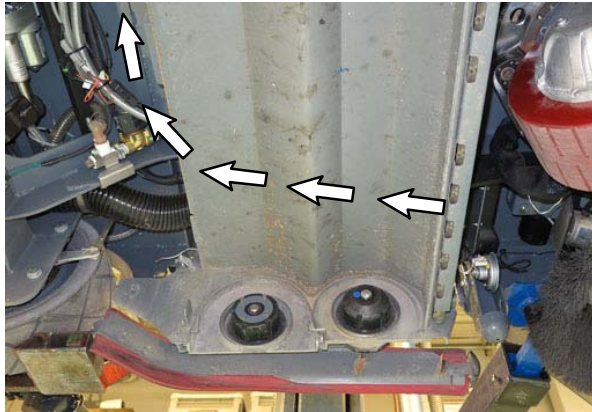

FIG. 12

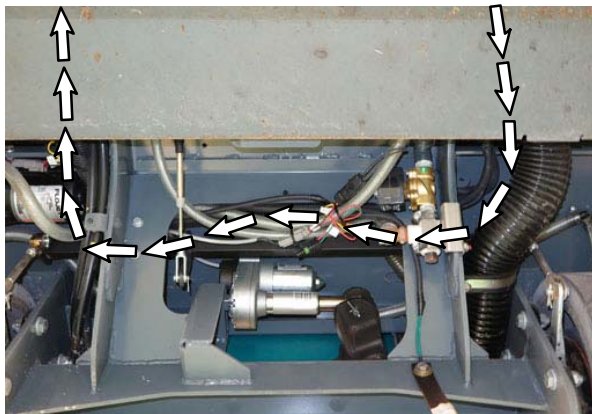

FIG. 13

16. Route the telemetry harness (12) lead to be connected to the 36 VDC contactor up into the electrical enclosure and connect the lead to the 36 VDC B+ at M1 contactor. (Fig. 14 / Fig. 11 / Fig. 17)

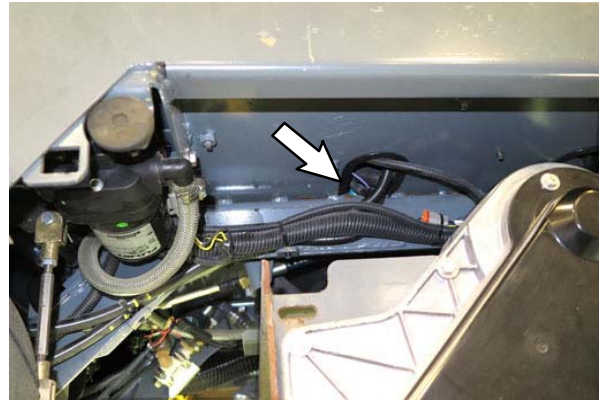

FIG. 14

17. Route telemetry harness (12) 13/BLK-WHT and 79/WHT leads along the battery cable (13) and up to the shunt (9).
18. Connect the telemetry harness (12) 13/BLK-WHT wire to the shunt (9) top terminal . (Fig. 15 / Fig. 17)

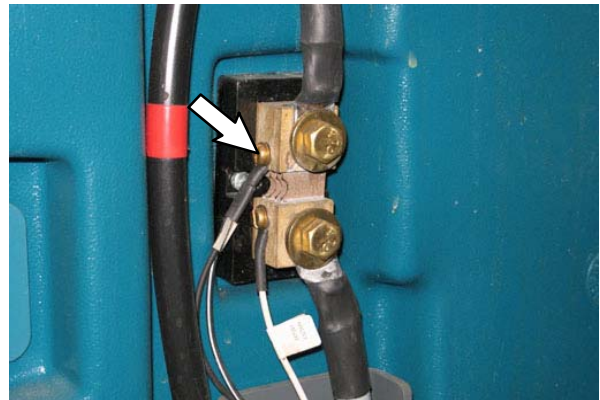

FIG. 15

19. Connect the telemetry harness (12) 79/WHT wire to the shunt (9) bottom terminal . (Fig. 16 / Fig. 17)



FIG. 16

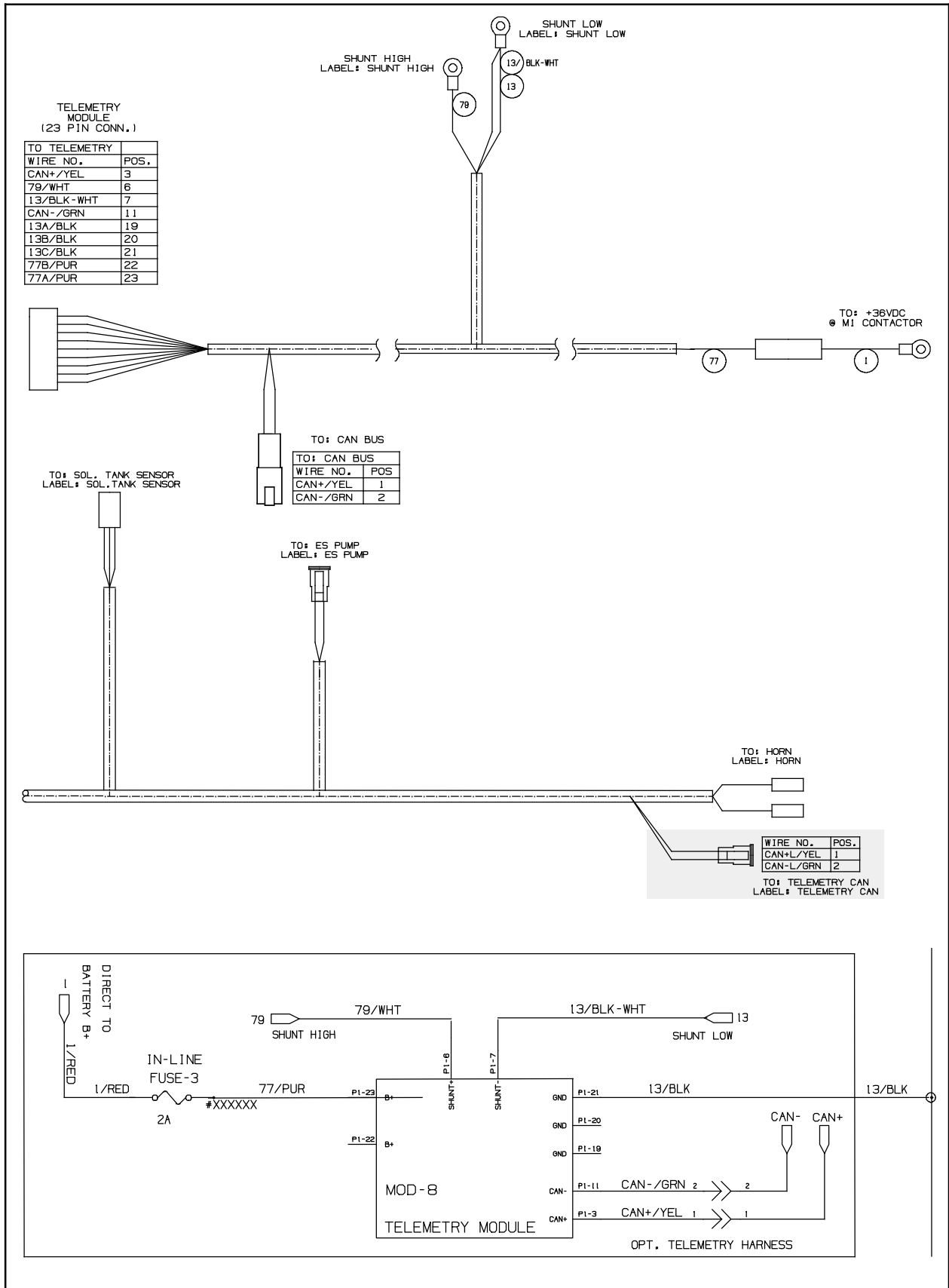

FIG. 17

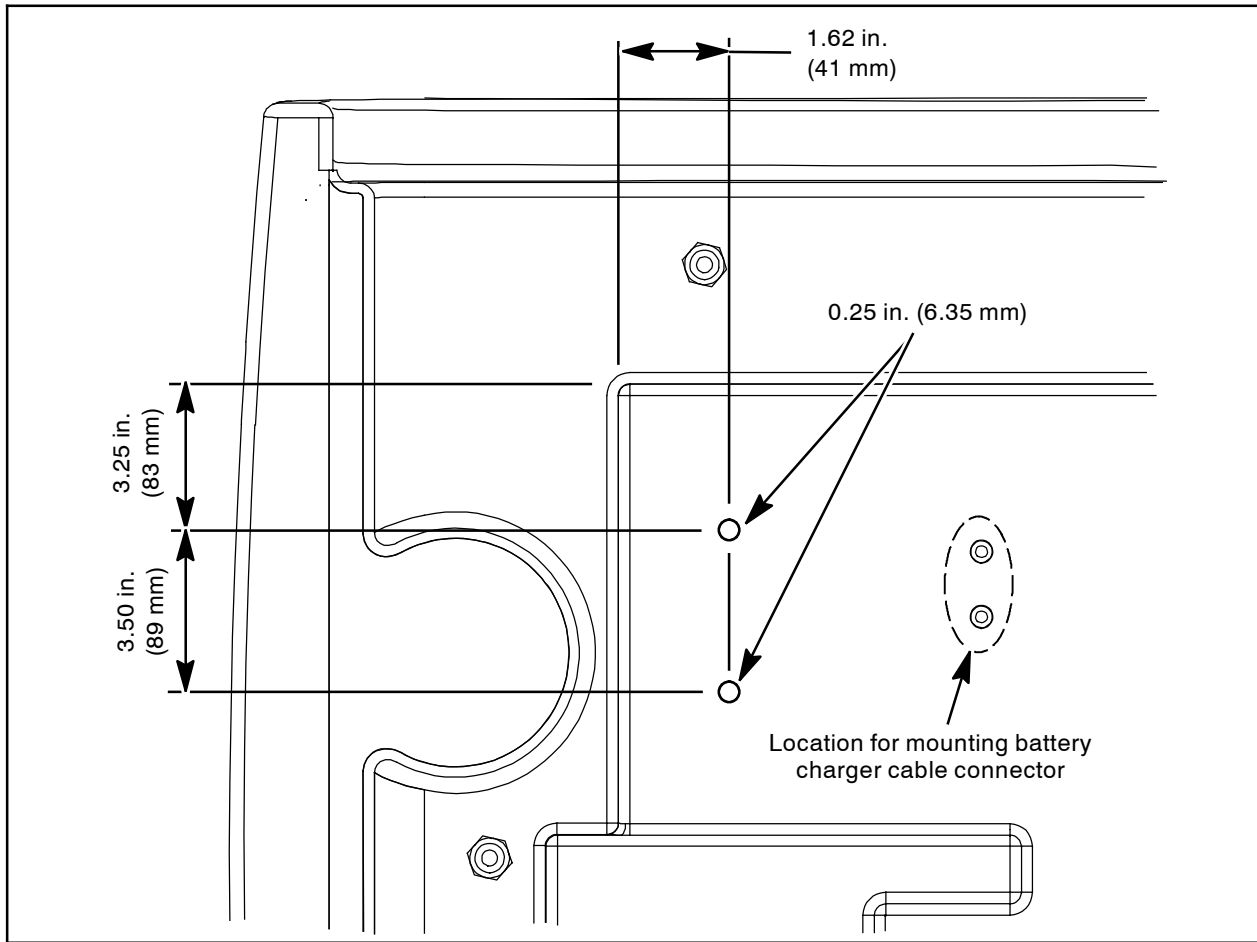

FIG. 18

20. Drill two 0.25 in (6.35 mm) holes into battery compartment cover. **Do Not** drill up into / through the top surface of the battery compartment cover. (Fig. 18)

22. Route the antenna (16) cable through the cable clamps, along the main battery cable (13) / telemetry harness (12), and to the telemetry control box (1). (Fig. 20)

21. Install a wire tie (17) into the 0.25 in. (6.35 mm) hole and use the wire ties to secure the antenna (16) to the battery compartment cover. (Fig. 19)

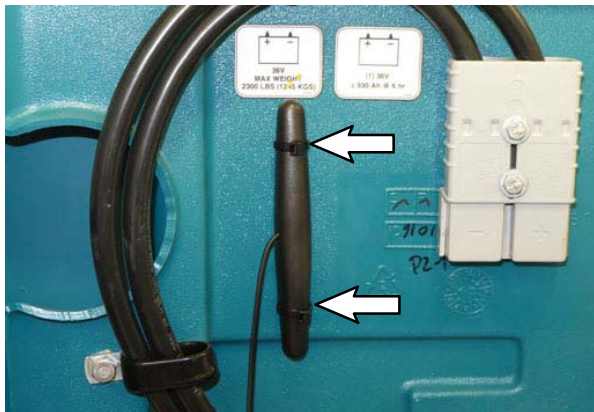

FIG. 19

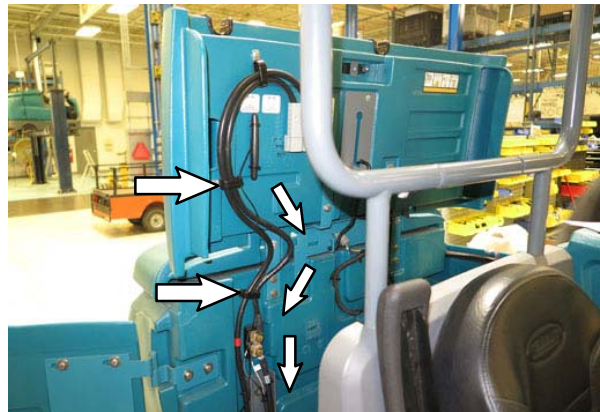

FIG. 20

23. Connect the antenna (16) cable to the telemetry control box (1). (Fig. 21)

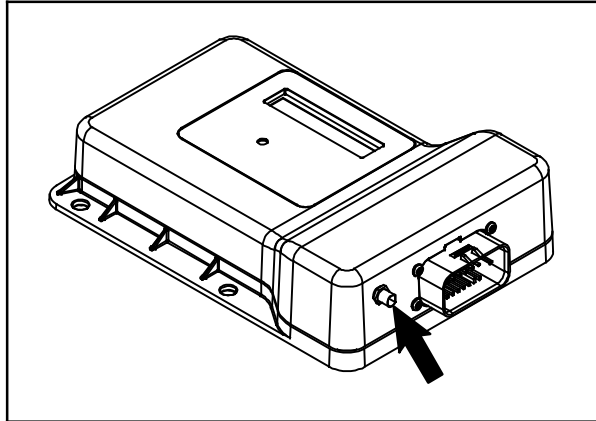

FIG. 21

24. Use cable ties (15) to secure the telemetry harness (12) and antenna (16) cable away from moving parts or areas where they can be caught or damaged.
25. Install the telemetry label (8) onto the electrical access panel. (Fig. 22)

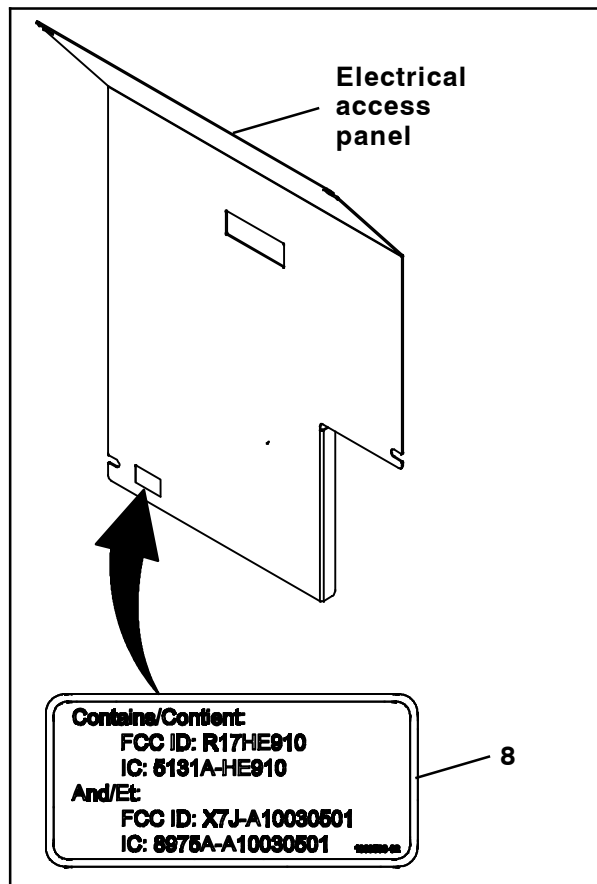

FIG. 22

26. Reinstall the electrical enclosure cover onto the electrical enclosure.
27. Reinstall the battery into the battery compartment and connect the battery cable to the machine.
28. Start the machine, raise the scrub head, and turn off the machine.
29. Reinstall the brushes into the main scrub head.
30. **Machines equipped with cylindrical brushes only:** Reinstall the debris trough onto the scrub head.
31. Start and test the machine.
32. .Activate the IRIS (telemetry module):

North America Customer Locations: Call Technical Support (between hours of 7:00 am and 5:00 pm CST) for assistance to activate the module. The IRIS telemetry system must be activated to complete this install. Have machine serial number and IRIS module SIM number ready when calling for activation

Australia Customer Locations: Call CCC (between hours of 8:00 am and 5:00 pm AEST) and ask to be routed to the IRIS expert for assistance to activate the module. The IRIS telemetry system must be activated to complete this install. Have machine serial number and IRIS module SIM number ready when calling for activation.

EU Customer Locations: Call local IRIS expert for assistance to activate the module. The IRIS telemetry system must be activated to complete this install. Have machine serial number and control box (1) SIM number ready when calling for activation.

NOTE: The IRIS (telemetry module) must be activated to complete this installation. The module will not function until it is activated. Call for assistance activating the module after all telemetry components have been installed.

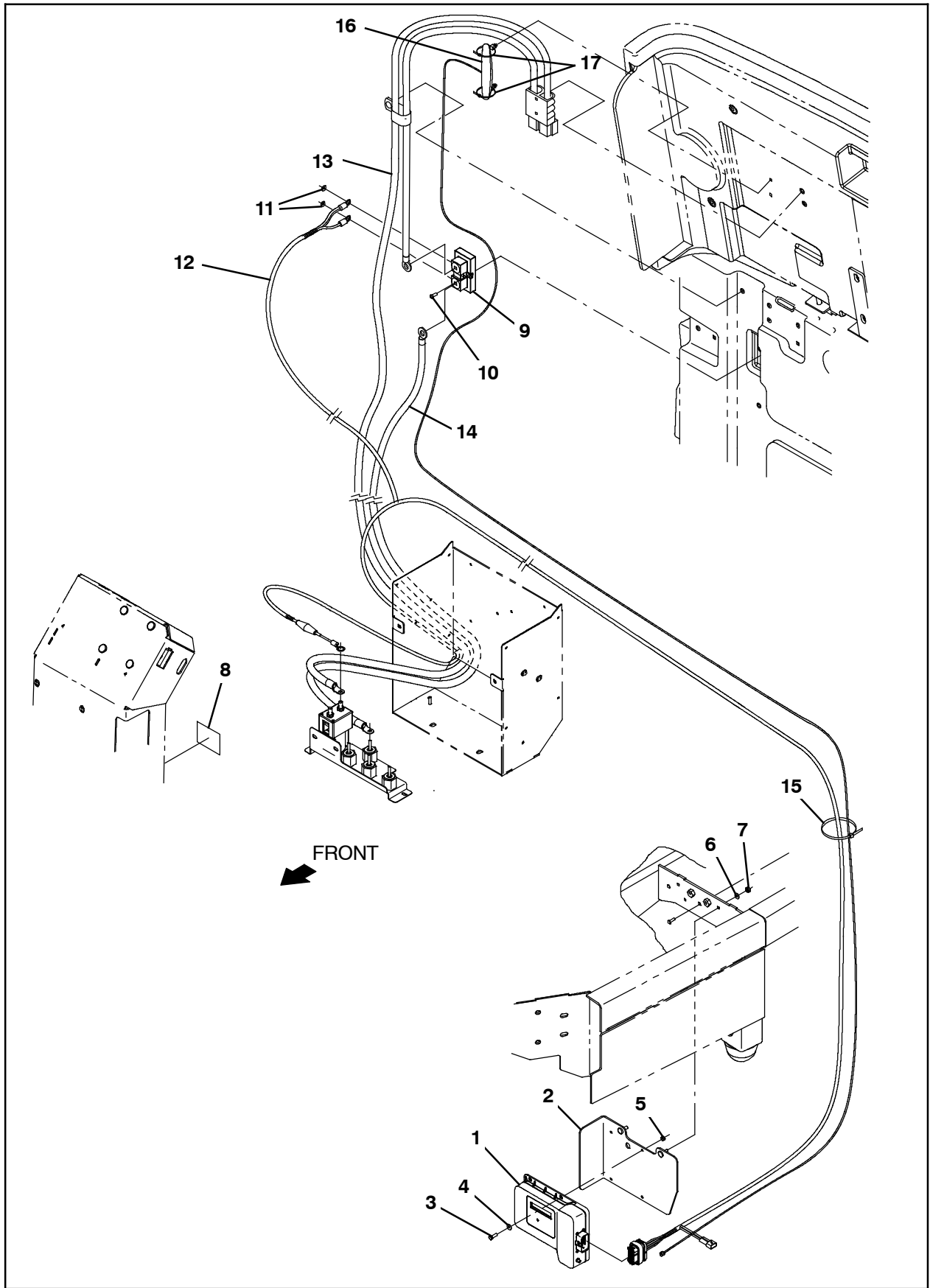

FIG. 23

Bill Of Materials For Parts Kit, w/Telem, US, CI - 9017311

Ref.	Tenant Part No.	Description	Qty.	
1	1069467	Control Box Assy, Telem [Int]	1	
2	1207701	Bracket Wldt, Mtg, Telem	1	
3	24199	Screw, Hex, M5 X 0.80 X 16, SS	2	
4	01683	Washer, Flat, 10, SS	2	
5	06549	Nut, Hex, Lock, M5 X 0.80, NI	2	
6	32483	Washer, Flat, 0.25, SAE	4	
7	08708	Nut, Hex, Lock, M6 X 1.00, NI	2	
8	1069580	Label, Opertnl, Telem [FCC/IC]	1	
9	1070757	Shunt, 050mv 400a	1	
10	06927	Screw, Pan, Phl, M4 X 0.70 X 16, 4.8	2	
11	07514	Washer, Lock, Int, 10, SS	2	
▽	12	1073059	Harness, Ele [Telemetry, T17]	1
▲		9009990	Fuse, 002a, 250vdc, Cartridge	1
13	1074600	Cable, Battery, 2/0GA [M17, Telem]	1	
14	1074601	Cable, 2/0Ga 61.0L Blk [M6 Ring/M9 Ring]	1	
15	130773	Tie, Cable, Nyl, 11.0l, 14w, 3.0 Max D	12	
16	1070658	Antenna, Telem, 187 In [GPRS]	1	
17	1210807	Wire, Tie [W/.25" Fir Tree Clip]	2	

Bill Of Materials For Parts Kit, w/Telem, Intl, CI - 9017314

Ref.	Tenant Part No.	Description	Qty.	
1	1070541	Control Box Assy, Telem [3G, Intl]	1	
2	1207701	Bracket Wldt, Mtg, Telem	1	
3	24199	Screw, Hex, M5 X 0.80 X 16, SS	2	
4	01683	Washer, Flat, 10, SS	2	
5	06549	Nut, Hex, Lock, M5 X 0.80, NI	2	
6	32483	Washer, Flat, 0.25, SAE	4	
7	08708	Nut, Hex, Lock, M6 X 1.00, NI	2	
8	1069580	Label, Opertnl, Telem [FCC/IC]	1	
9	1070757	Shunt, 050mv 400a	1	
10	06927	Screw, Pan, Phl, M4 X 0.70 X 16, 4.8	2	
11	07514	Washer, Lock, Int, 10, SS	2	
▽	12	1073059	Harness, Ele [Telemetry, T17]	1
▲		9009990	Fuse, 002a, 250vdc, Cartridge	1
13	1074600	Cable, Battery, 2/0GA [M17, Telem]	1	
14	1074601	Cable, 2/0Ga 61.0L Blk [M6 Ring/M9 Ring]	1	
15	130773	Tie, Cable, Nyl, 11.0l, 14w, 3.0 Max D	12	
16	1070658	Antenna, Telem, 187 In [GPRS]	1	
17	1210807	Wire, Tie [W/.25" Fir Tree Clip]	2	
18	39358	Washer. Lock, Int, 0.44	2	

TENNANT COMPANY
P. O. Box 1452
Minneapolis, MN 55440-1452